



Effects of Soil Resistivity Variation with Depth on Crop Yield in a Typical Sedimentary Terrain, Igeduma-Edo State, Nigeria: A Geophysical Method Application in Agricultural Practice

 **Aigbedion I.**

Geophysics/Physics Department, Ambrose Alli University, Ekpoma, Nigeria
Email: isaacaiqbedion@yahoo.com

*(Corresponding author)

 **Salufu S.O.**

Geophysics/Physics Department, Ambrose Alli University, Ekpoma, Nigeria
Email: isaacaiqbedion@yahoo.com

 **ILUGBO STEPHEN OLUBUSOLA***

Geophysics/Physics Department, Ambrose Alli University, Ekpoma, Nigeria
Email: bussytex4peace44@gmail.com

Article History

Received: 7 April 2022

Revised: 13 June 2022

Accepted: 19 June 2022

Published: 25 June 2022

How to Cite

Aigbedion, I., Salufu, S. O. and ILUGBO, S. O. (2022). Effects of Soil Resistivity Variation with Depth on Crop Yield in a Typical Sedimentary Terrain, Igeduma - Edo State, Nigeria: A Geophysical Method Application in Agricultural Practice. *Sumerianz Journal of Agriculture and Veterinary*, vol. 5, pp. 34-43.

Abstract

Accurate knowledge of soil fertility is required to promote global food security for life sustenance. Literatures have shown that electrical resistivity method is effective for agricultural site selection without passing through the rigor of soil test. However, the factor responsible for inconsistency in resistivity signature with soil fertility from one place to another, effect of soil texture and depth variation on crop yield are the questions this work geared at providing answers. Ten Vertical Electrical Sounding (VES) were conducted across the study area using Schlumberger array. Res1Dinvers was used for the inversion model, using Least Square method. Twenty soil samples were obtained in the VES points, two samples per point. One sample each at first and second layer. Result of the apparent resistivity showed that areas with high-excellent crop yield have resistivity signature above 500 Ωm while areas with low yield are characterized by values less than 500 Ωm . In both areas of low and high-excellent crop yield, the result of geochemical analysis indicated that Nitrogen, phosphate, and Potassium varied as 59-61%, 43-54mg/kg and 49-51mg/kg, respectively except for organic matter content that was above 3.8% in the first layer have high-excellent yield while low yield soil showed less than 3.8% in their first layer and even if the second layer's organic matter is above 3.8%. This study has shown that organic matter has significant effect on soil resistivity signature than others soil nutrients (Phosphate, Potassium and Nitrogen). The study shows that soil's first layer (0-0.3m) is the most suitable depth conducive for soil minerals occurrence for optimum agricultural output.

Keywords: Vertical electrical sounding; Soil texture; Soil nutrients; Water table; Electrical resistivity.

1. Introduction

Food security is an essential tool for life sustenance in the globe [1]. Agricultural output optimization is the key to food security in the globe. There won't be optimum output of crop yield in agricultural practice, needed for actualization of food security for life sustenance across the globe if the soil meant for cultivation of crops is not fertile. The question is how can fertile soil be identify without going through stress of digging the soil, collection of several thousand of soil samples, without passing through the rigor of soil test and the financial implications involved? The answer is, an alternative easier and convenient method is needed, that can, on a large scale identify soil with good texture and nutrient contents, favorable for high yield crops for food security actualization. Most

importantly, the first step to achieve optimization of agricultural output is to identify fertile soil that can give high yield crops. Geophysical methods have been found to be relevant in agricultural practice and their applications have been demonstrated in the literatures [2-5].

Geophysical soil mapping for spatial essential soil nutrients distribution (SESND) has become important in agricultural planning in recent times. Spatial soil nutrients mapping has been of high practice by several European countries [6]. Non-invasive Geophysical mapping is a vital tool to meet up with this new trend [7, 8]. Corwin and Lesch [9]; Aigbedion and Salufu [10] extensively gave descriptions on the techniques, principles of electrical resistivity method and its applications in agricultural practices. Werban, *et al.* [7], used geophysical mapping to correlate electrical resistivity of soil parameters and soil fertility. They noticed that organic content, clay content, and bulk density of soil have good correlation with soil resistivity. Similar observation has been noticed in the existing literatures [11-14]. However, this present work is geared at carrying out a study to identify which of the soil nutrients (organic matter of soil, phosphate, nitrogen or potassium content of soil) is the most suitable to determining the relevant soil resistivity signature for high yield soil (fertile soil), the most important parameter that gives optimum agricultural output or if other nutrients are needed, the effect of soil texture on crop yield and the effect of depth variation on crop yield.

2. Site Description

The study area covers Igieduma, Ukpoh, Ukpohi, and Ehor in Edo State, Nigeria (Figure 1). The area is accessible by one major road, Benin-Auchi Road. The topography of the area ranged from 783ft to 815ft that forms a general gentle slope which appears as slight hill at the eastern part and low land to valley towards the west of the area (Figure 1). Igieduma, Ehor and neighboring villages are known for agricultural activities. The villages are the food basket of Edo State where agricultural produce come from, to other parts of the state and outside the state. The famers in the area cultivate cassava, yam, potatoes, cereals, pepper, tomatoes, vegetable and cash crops such as rubber.

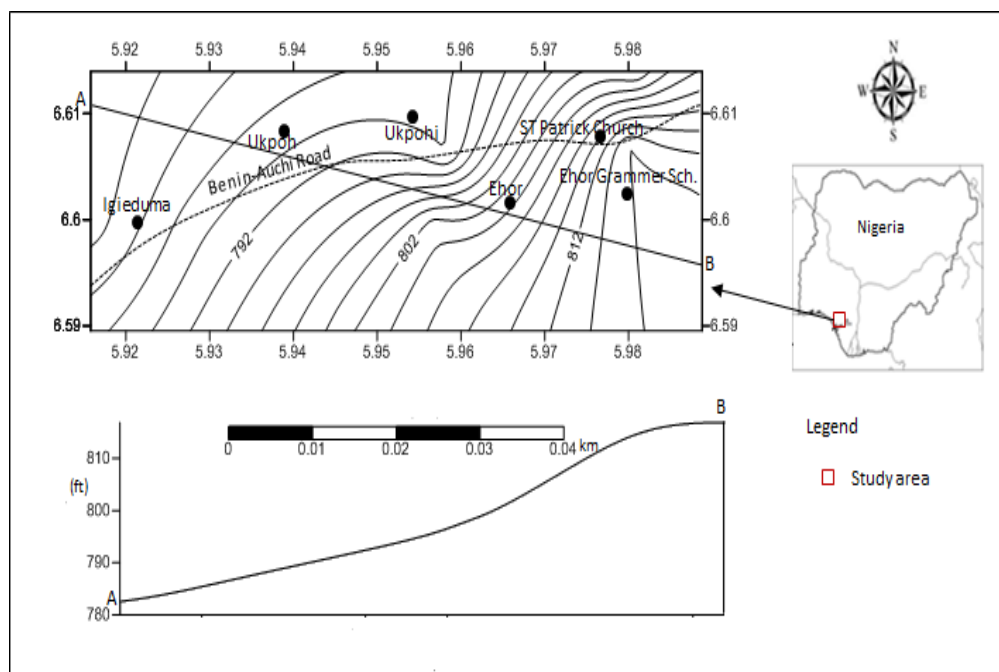

Figure-1. Map of the study area, Igieduma and Environs, Edo State-Nigeria .

3. Materials and Methods

Ten Vertical Electrical Sounding (VES) points were spread across the study area covering Igieduma, Ukpohi, Ukpoh, and Ehor in Edo State, Nigeria, using SAS 1000 ABEM. The spreading of each VES point was in such a way that the crop yield around each point was first identified to know if is high, moderate, or low yield crops. The VES were done to determine the soil resistivity and water table of the area. The resistivity from topsoil to 0.3m depth and from 0.3m to 2m depth was specifically acquired in order to identify the effect of soil resistivity variation with depth on crop yield. Schlumberger Array method was adopted in the study with AB/2 values ranging from 0.5m-200m and MN/2 ranging from 0.2m-20m. The resistivity field result was modeled using RES1Dinvers. The inversion model was carried out based on Least square method.

Twenty samples of soil were obtained from the ten VES points across the study area for plant essential nutrients (organic soil nutrient; organic matter and inorganic soil nutrients or mineral nutrients; Nitrogen, Phosphorus, and Potassium) test, Ph test, and soil textural analysis or grain size analysis. These analyses were done using standard method. Ten soil samples were obtained from the topsoil to 0.3m and another set of ten soil samples were also obtained from depth of 0.3m to 2m in order to carry out the analyses. The result of soil textural analysis was plotted on triangular plot for soil type identification in the study area.

Global Positioning System (GPS) was used to geo-reference the point of data acquisition in the study area in order to identify spatial variation of soil resistivity, soil organic nutrient, soil mineral nutrients, soil grain size, and crop yield, across the study area using Geographical Information Science (GIS). The result of the soil resistivity, soil nutrient analysis, soil textural analysis, were integrated and compared using descriptive statistical method in order to identify the effect of soil resistivity variation with depth on crop yield.

4. Theoretical Framework

A pair of current electrodes KL and a pair of potential electrodes MN were arranged as shown in Figure 2. Electrodes K acts as source while L acts as sink. At electrodes M, the potential due to source K is given as, according to Lowrie [15].

$$+ \frac{\rho I}{2\pi r_{KM}}$$

While the potential due to sink L is given as:

$$- \frac{\rho I}{2\pi r_{ML}}$$

The combined potential at M is

$$U_M = \frac{\rho I}{2\pi} \left(\frac{1}{r_{KM}} + \frac{1}{r_{ML}} \right) \quad (1)$$

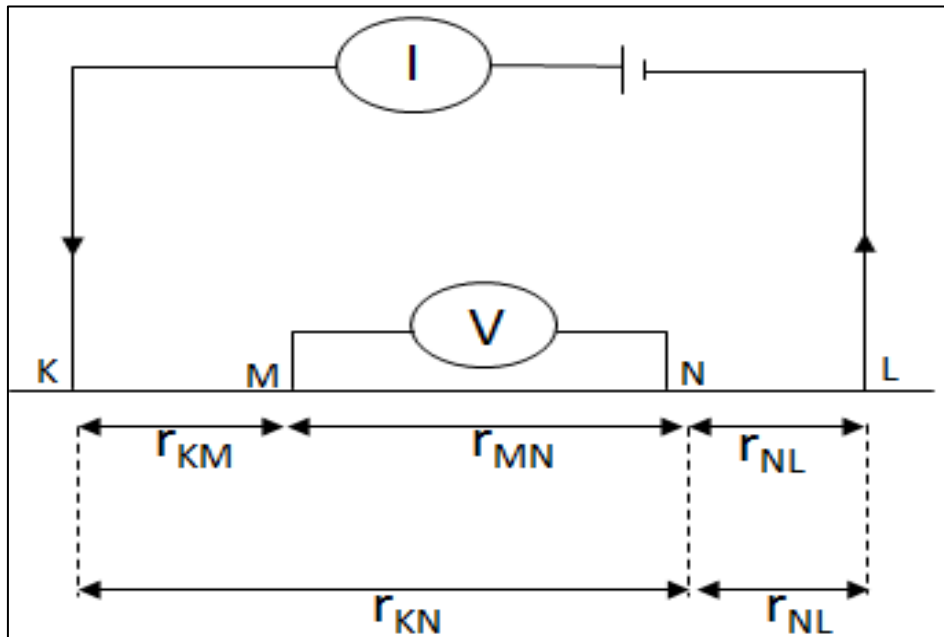

Figure-2. Diagrammatical illustration of resistivity method

Also at N, the result potential is expressed as

$$U_N = \frac{\rho I}{2\pi} \left(\frac{1}{r_{KN}} - \frac{1}{r_{NL}} \right) \quad (2)$$

The potential difference between MN is given as:

$$V = U_M - U_N \quad (3)$$

$$V = \frac{\rho I}{2\pi} \left[\left(\frac{1}{r_{KM}} - \frac{1}{r_{ML}} \right) - \left(\frac{1}{r_{KN}} - \frac{1}{r_{NL}} \right) \right] \quad (4)$$

Therefore, resistivity (ρ) of the soil is given as:

$$\rho = 2\pi \frac{V}{I} \left[\frac{1}{\left(\frac{1}{r_{KM}} - \frac{1}{r_{ML}} \right) - \left(\frac{1}{r_{KN}} - \frac{1}{r_{NL}} \right)} \right] \quad (5)$$

Schlumberger array (Figure 3) was used for data acquisition in the field, hence apparent resistivity ρ_a be Using Figure 5,

$$r_{KM} = \frac{(L-a)}{2} \quad (6)$$

$$r_{ML} = \frac{(L+a)}{2} \quad (7)$$

$$r_{KN} = r_{ML} \quad (8)$$

$$r_{NL} = r_{KM} \quad (9)$$

Therefore, apparent resistivity of the soil is given as:

$$\rho_a = \frac{\pi V (L^2 - a^2)}{4 I a} \quad (10)$$

where,

V=Potential difference

I=Electric current

a=Distance between the potential electrodes

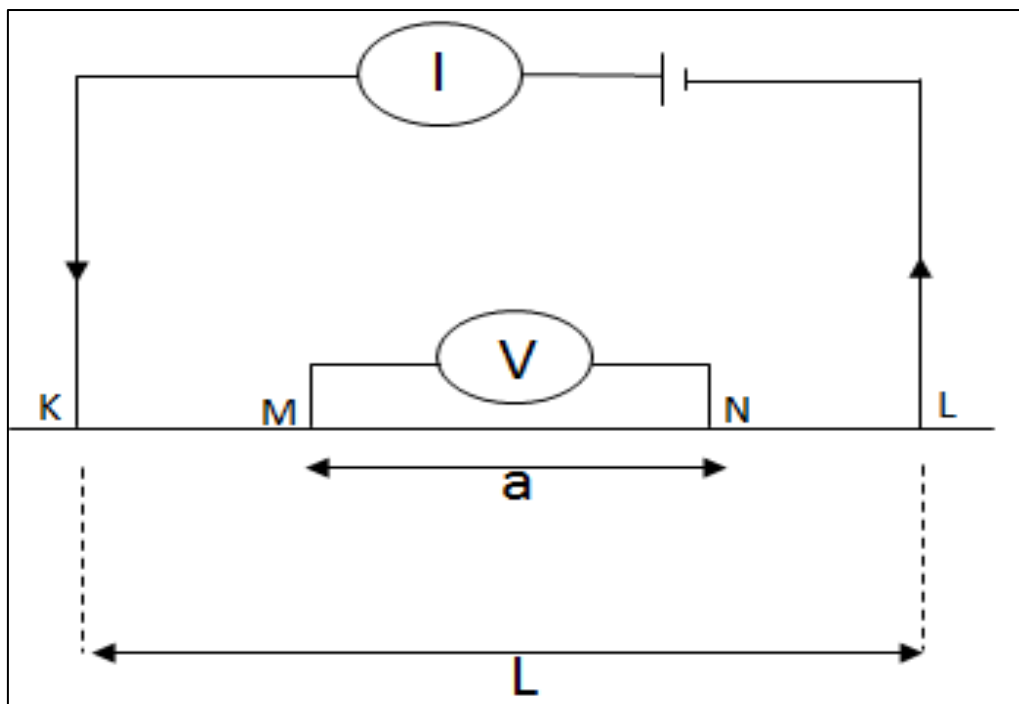

Figure-3. Schlumberger array method

Least square method was used to carry out the inversion model for the resistivity data as follows:

$$(J^T + \lambda I)\Delta q_k = J^T g \tag{11}$$

where q = model parameter vector

g = vector discrepancy

Δq_k = difference in the parameter of model

λ = factor for damping

I = Identity matrix

However, the Jacobian matrix is expressed using partial derivative as follow:

$$J_{ij} = \frac{\partial j_i}{\partial q_i} \tag{12}$$

5. Results and Discussion

The resistivity values in VES 1 and VES 2 ranged from 90 to 40,000 Ωm (Figure 4) in Igieduma while in Ehor, VES 3, VES 5, VES 6 VES 8, and VES 10 resistivity values ranged from 80 Ωm to over 20,000 Ωm (Figure 5). The VES results show that the Igieduma water table varies from 150 to 160 m, Ukpohi ranged from 140 to 160 m, and Ehor varies from 80 to 115 m. This result is an indication that the water table is relatively deep and it will not give room for flooding and over-saturation of soil pores spaces in the vadose zones (Table 1).

Table-1. Water Table results of the study area

VES	Location	Water Table (m)
1	Igieduma	160
2	Igieduma	155
3	Ehor	110
4	Igieduma	150
5	Ehor	115
6	Ehor	110
7	Ukpohi	140
8	Ehor	80
9	Ukpoh	160
10	Ehor	120

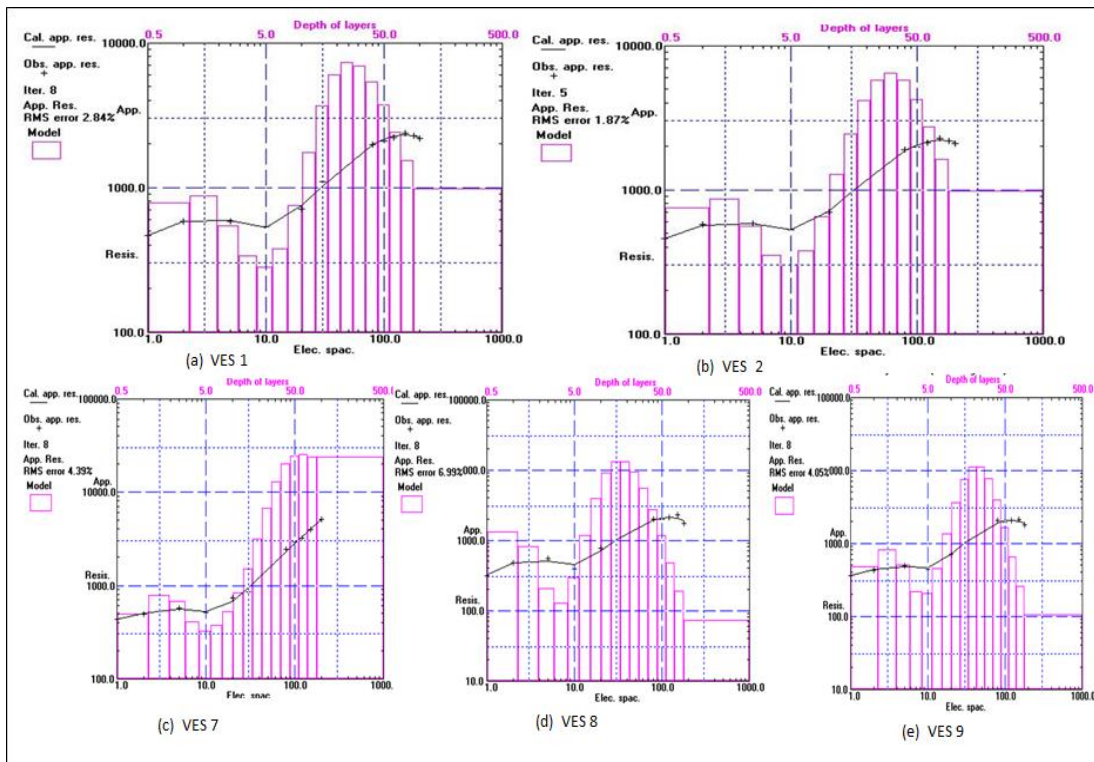

Figure-4. Inversion model for resistivity data acquired in Igeduma and adjacent vallages (Ukpho and Ukphi), Edo State

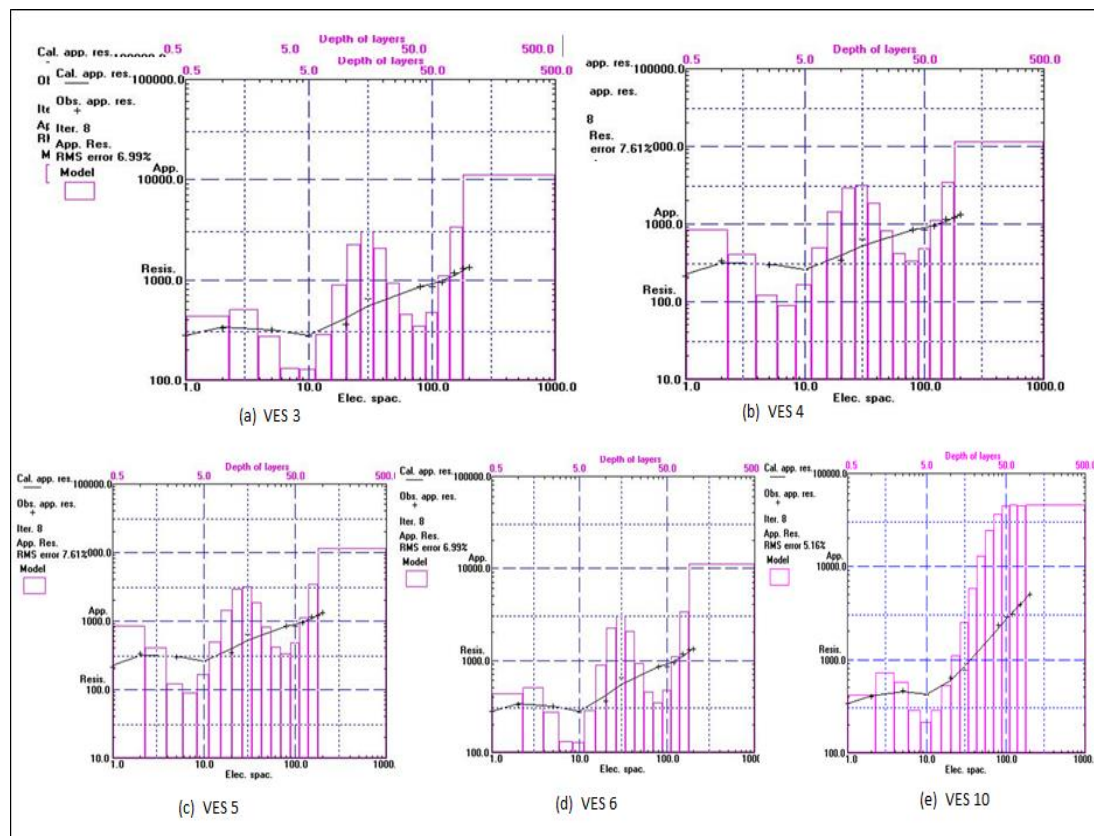

Figure-5. Inversion model for resistivity data acquired in Ehor, Edo State Nigeria

Geochemical result of the soil in the study area showed that the pH values fall within the required range for agricultural purposes (Table 2 and 3). Nitrogen, Phosphorus, and potassium are in appreciable percentage (Table 2 and 3) that is required for good agricultural yield. Organic matter of the soil in Igeduma, Ukpho, Ukphi and Ehor at sample collection points S₁, S₂, S₃, S₄, S₅ and S₆ ranged from 4.24% to 4.47% (Table 2 and 3). However, organic soil content at sample collection points S₇, S₈, S₉, S₁₀ are less than 4.0% as shown in Table 3. Soil with organic matter less than 3.8 % showed resistivity signature ranged less than 500 Ωm while soil with organic matter above 3.8% gave resistivity signature above 700 Ωm as shown in Table 2 and 3. Textural analysis result shows that the soil is richest in silt with the silt percentage ranging from 77.3-81.4% followed by clay 13.0-14.4% while sand is the least percentage (Table 2 and 3). The high content of silt and clay is evidence that soil nutrients will be retained for any crop planted in that area to absorb optimally for high yield. Hence, this study has shown the reason farm produce

in the study area often give high yield, because the textural composition and soil nutrients are in right proportions that promotes high yield except for minor places such as points S₇ and S₁₀ where sandstone has highest percentage of 71%-81% (Table 3). The crop yield around these points in the field showed low yield. This observation indicates that largest percentage of sand than clay and silt gives room for excessive infiltration of soil nutrients into the soil, below the reach of crop roots hence, the crops around such area will yield low as a result of nutrients deficiency due to depth leaching into formation beneath.

Table-2. Correlation of soil resistivity values and basic soil nutrient of soil in the study area

Soil Parameters	S1 ₁	S1 ₂	S2 ₁	S2 ₂	S3 ₁	S3 ₂	S4 ₁	S4 ₂	S5 ₁	S5 ₂
Resistivity (Ωm)	790	900	760	900	780	900	760	910	760	900
pH	6.7	6.8	6.8	6.7	6.7	6.9	6.8	6.8	6.8	6.7
Organic matter (%)	4.24	4.50	4.35	4.37	4.25	4.40	4.45	4.47	4.35	4.27
Total Nitrogen (%)	62.10	65.21	60.10	56.00	62.20	65.11	60.20	56.20	60.10	54.00
Phosphorus (mg/kg)	54.22	50.23	43.14	44.00	53.22	51.23	44.14	43.00	43.14	44.00
K (mg/kg)	54.1	51.2	50.2	51.2	53.1	52.2	51.2	51.3	50.2	51.2
Sand (%)	5.5	10.5	9.4	7.9	5.4	10.5	10.4	6.9	9.4	7.9
Silt (%)	81.4	79.2	77.3	79.1	81.5	80.2	77.3	80.1	77.3	79.1
Clay (%)	13.1	13.1	13.3	13.0	13.1	12.1	12.3	13.0	13.3	13.0

S1₁, S2₁, S3₁, S4₁, S5₁- soil samples for the first layer (topsoil)

S1₂, S2₂, S3₂, S4₂, S5₂- soil samples for the second layer

Table-3. Correlation of soil resistivity values and basic soil nutrient of soil in the study area

Soil Parameters	S6 ₁	S6 ₂	S7 ₁	S7 ₂	S8 ₁	S8 ₂	S9 ₁	S9 ₂	S10 ₁	S10 ₂
Resistivity (Ωm)	760	910	440	410	750	520	815	415	440	510
pH	6.8	6.8	6.9	6.8	6.8	7.1	6.9	6.8	6.8	7.1
Organic matter (%)	4.45	4.47	3.62	4.02	3.34	3.41	3.61	3.35	3.24	3.51
Total Nitrogen (%)	60.20	56.20	51.20	60.10	61.20	60.10	60.20	60.10	51.20	60.20
Phosphorus (mg/kg)	44.14	43.00	47.02	53.21	43.02	46.02	47.01	52.21	42.02	47.02
K (mg/kg)	51.2	51.3	51.2	50.3	49.5	49.7	50.2	50.3	50.1	49.8
Sand (%)	10.4	6.9	80.0	72.1	18.7	7.1	5.9	7.1	81.0	71.0
Silt (%)	77.3	80.1	18.0	6.3	81.0	71.7	81.0	79.3	18.0	8.00
Clay (%)	12.3	13.0	2.0	21.6	1.3	21.2	13.2	13.6	1.00	21.0

S6₁, S7₁, S8₁, S9₁, S10₁- soil samples for the first layer (topsoil)

S6₂, S7₂, S8₂, S9₂, S10₂- soil samples for the second layer

6. Correlation of Soil Resistivity with Crop Yield and Basic Soil Nutrients

Spatial distribution of soil resistivity across the study area showed that the north and north central of Igiedume, Ukpohi, and Ukpoh have the highest resistivity values ranging from 800Ωm to over 900 Ωm from the first to second layer. The crop yield around the areas with this resistivity range is extremely high yield according to the field observation of crops as at the time of data acquisition (Figure 6). The north west of Igiedume through the southern portion of Igiedume down to other part of Ukpoh, Ukpohi, and the entire area of Ehor have soil resistivity that ranges from 640 Ωm to 780 Ωm with high yield crops except the central part of Ehor that ranged from 420 Ωm to 500 Ωm as shown in Figure 6 has low yield. These patterns of crop yield trend with the trend of soil resistivity values in the study area gives a strong evidence of correlation existence between soil resistivity values and crop yield. This correlation is a factor of soil texture, soil nutrients and water table. If the soil texture and soil nutrients are in good proportion and the water table is relatively favorable, then the crop yield will be optimum. Similar to the laboratory observation made by Islam, *et al.* [8].

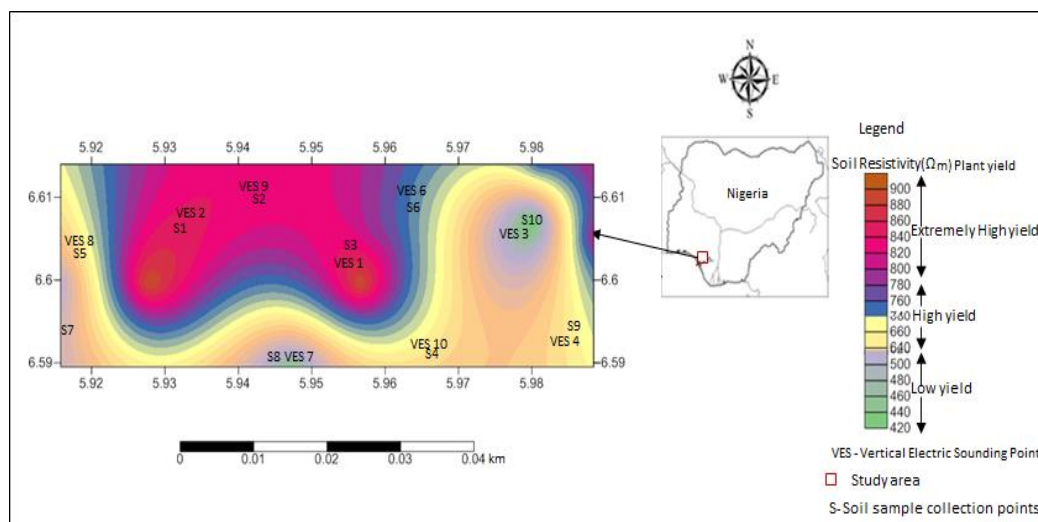

Figure-6. Spatial distribution of soil resistivity and crop yield in the study area

7. Effects of Depth Variation, Soil Texture and Soil Nutrient Contents on Crop Yield

At depth of 0.3 m from the surface, area with spatial distribution of Nitrogen content of 60-65.5% (Figure 7a), organic matter content of 3.8-4.55% (Figure 7b), Potassium content of 1-54 mg/kg (Figure 7c) with silty loam soil as shown in soil textural plot in Figure 8 and Figure 9d, generally has resistivity values that ranged from 700 Ω m to 900 Ω m (Figure 7e and 9c). The yield of the crops in the area is high to extremely high yield in the study area as shown in Figure 7d. However, areas that Nitrogen content of the soil drops below 60%, Potassium content of the soil drops below 51 mg/kg to 51.4mg/kg, organic matter content of the soil drops below 3.8% to 3.55%, with silty loam soil texture showed resistivity signature values that ranged from 540 Ω m to 700 Ω m. The yield of the crops in this resistivity range was good to moderate yield in the study area. However, areas with spatial distribution of soil Nitrogen content below 60% with soil Potassium content of less than 51.4mg/kg, soil organic content below 3.55% with sandy loam soil texture, generally have low yield in the study area.

The observed variations in soil minerals, soil minerals percentage content and type of soil texture cumulate to vary soil resistivity signature values observed in the study area. The pattern of resistivity signature response to the percentage and the proportion of organic matter, phosphorus, nitrogen and potassium contents of the soil in the study area show that organic matter content of the soil is the most influencing soil mineral among the four listed above that determining the value and pattern of soil resistivity signature. At samples collection points; 1, 2, 3, 4, 5, 6, 8 and 9, high- excellent high yield crops were observed. In these point, their potassium, nitrogen, phosphorus contents of the soil around those point were almost having same values with sample collection points 7 and 10 whose crop yield were low. However, the only different is those with high-excellent yield have organic matter above 3.8% while those with low yield have below 3.8% organic matter. Though other factors can still affect, like soil water content. In this work, the field data acquisition was done in dry season.

However, from depth of 0.3 m to 2m, the soil parameters and resistivity signature values of the soil changed from what was obtained at the surface to depth of 0.3 m (shallow depth). Soil at the second layer (deeper depth), Nitrogen, Phosphorus, and Organic matter contents of the soil were found to be slightly lower (Figure 9a) compare to the values of soil obtained in the first layer of areas with excellence yield crops and high yield crops (Figure 9d). Except for Phosphorus soil content that is higher than the first layers soil as shown in Figure 9a. However, areas with low-moderate yield crops have their second layer's soil higher in organic matter content as shown in points 7 and 10 of Figure 9b except for point 9 that has high yield crops. The resistivity of the soil in these areas is generally below 500 Ω m for both first and second layers except for point 9 (Figure 9c). This observation may be due to textural contents of the soil in areas with low-moderate crop yield. Because the textural analysis shows that the first layer is sandy loam while the second layer is sandy clay loam. The sandiness of the area must have allowed air and rain water to easily penetrate into the soil thus enhanced oxidation, thereby reducing the content of organic matter at that layer which would have been available for crop to absorbed nutrient for high yield. The rain water that passes through the pores spaces of the sand grain must have encouraged easy infiltration of some of the organic matter in the first layer into the second layer. As result of the infiltration, more organic matter was washed down to the second layer. The textural combination of clay and sand in the second layer must have retained organic matter that has infiltrated from upper layer to be trapped in the second layer, because the presence of clay must have offered low permeability to the flow of organic matter from infiltrating further into the subsurface.

Although, despite higher Organic matter content observed in the second layer around areas with low-moderate crop yield and the areas still have low yield, it shows that crops root do not get into such depth to tape soil nutrients. To corroborate this fact, it will be noticed that other areas where organic matter is higher in the first layer than the second layer have excellent and high yield crops as shown in Figure 9b and 9d.

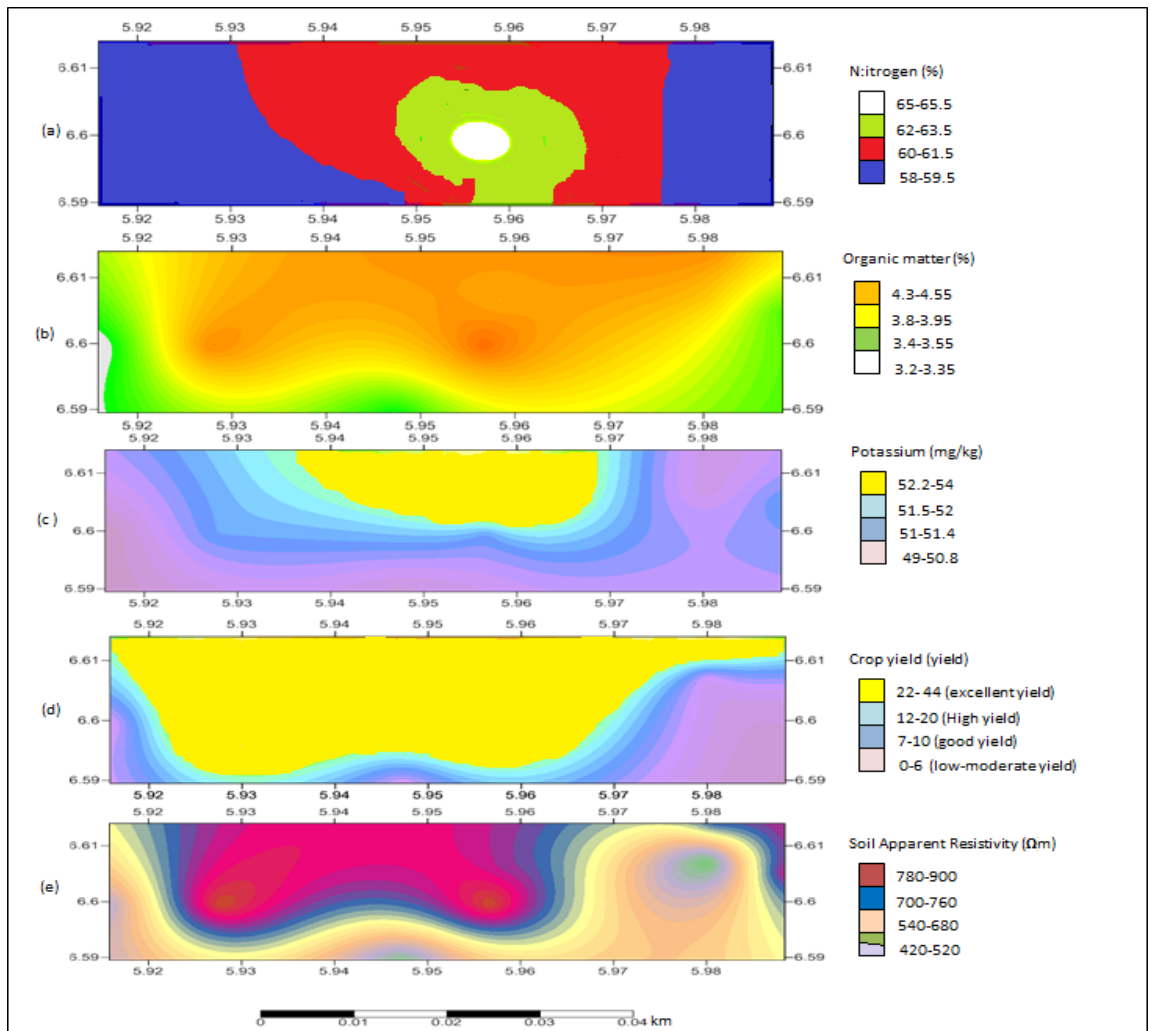

Figure-7. Comparison of spatial distribution of basic soil nutrients, soil resistivity, and crop yield in the study area

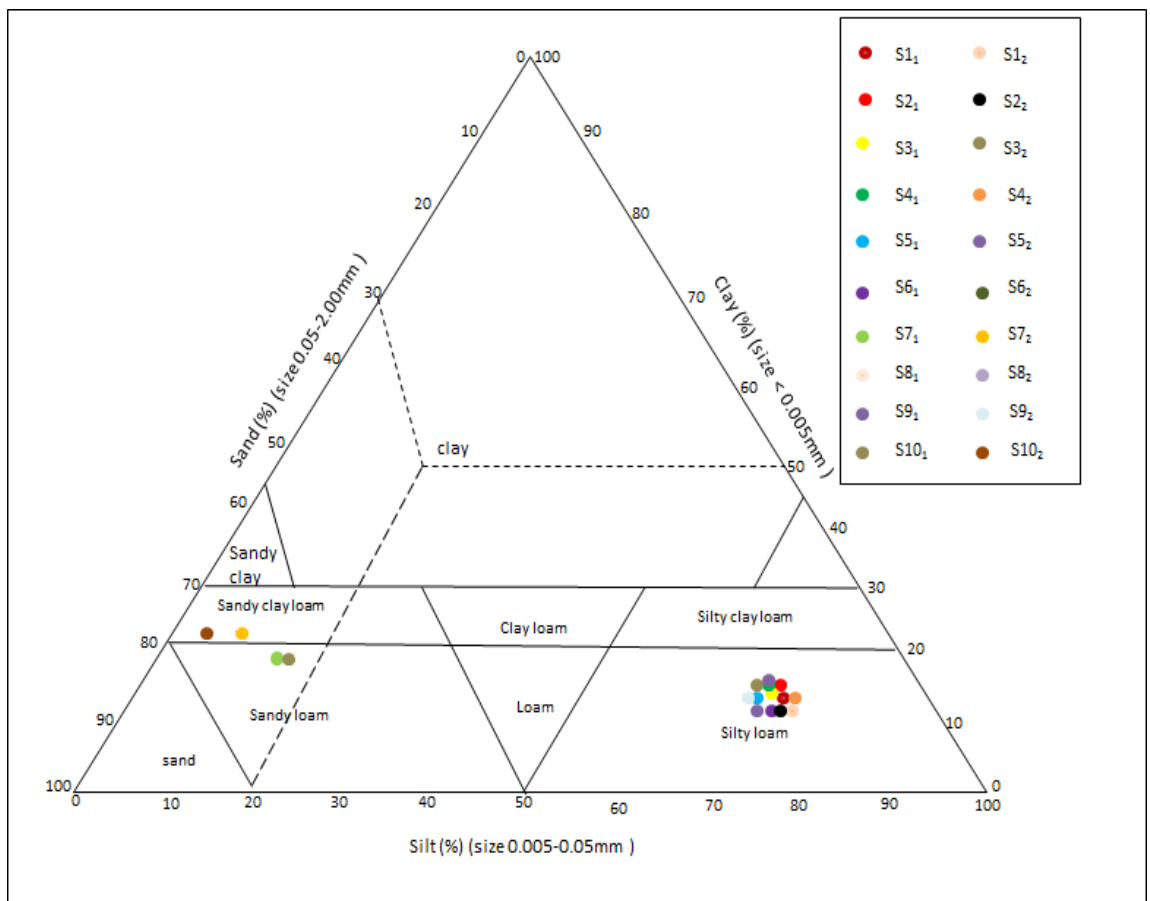

Figure-8. Traingular plot for textural analysis of soil samples in layers in the study area

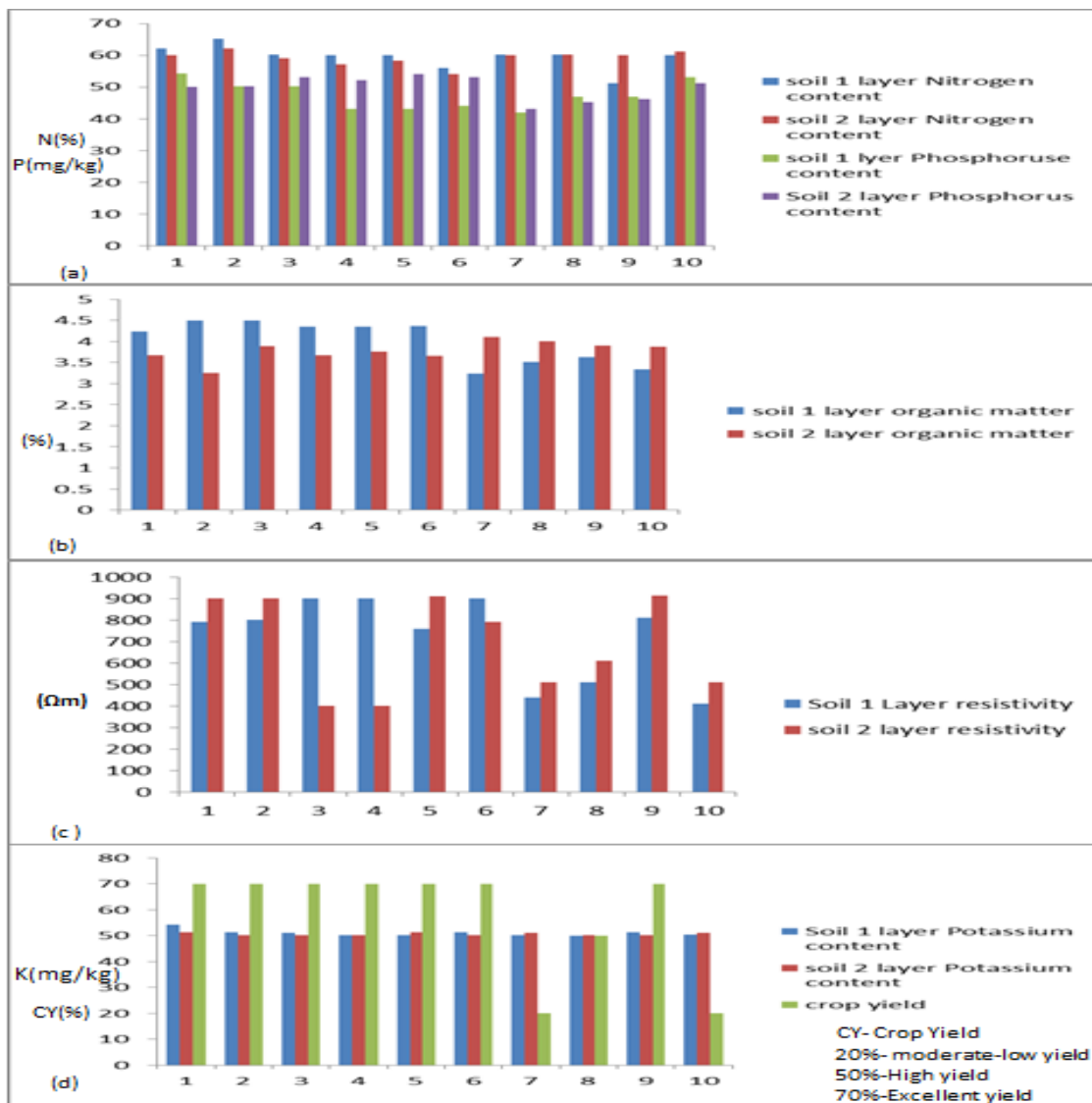

Figure-9. Descriptive statistical analyses of basic soil nutrients, soil resistivity, and crops yield in the study area

8. Conclusion

Application of geophysical resistivity method to determine soil fertility has been successfully done. The study shows that soil resistivity variation is a soil fertility signature that indicates how rich or poor a soil is in soil nutrients or minerals (organic matter, nitrogen, potassium and phosphorus). The study also shows that organic matter is the most dominant soil nutrient that determines the soil resistivity values and pattern out of the four basic nutrients studied. Soil texture is the major factor that controls soil nutrients variation with depth and laterally. Soil texture with highest percentage of silt in the study area showed the best soil nutrients retention than soil texture with highest percentage of sand. First layer (0-0.3m) of soil in the study area showed layer most suitable for soil nutrients habitation for easy access for plants for their high yield growth if appropriate nutrients are available in good proportion. Even, if soil nutrients are available in adequate proportions in other layers other than the first layer, such nutrients are not accessible and available to the plants/crops. Hence, crops planted in such area will produce low yield.

This study has shown that electrical resistivity geophysical method can be conveniently used to identify areas with high yield soil in order to boost optimum global food production for food security. However, caution should be made while using electrical resistivity method to determine suitable area with high yield by first carrying out a vanguard correlative study of soil resistivity and soil mineral test before using only electrical resistivity method extension to other areas in a given place because geochemical soil contents varies from place to place due to variation in geological terrain across places.

References

- [1] FAO, 2017. *The state of food security and nutrition in the world 2017. Building resilience for peace and food security.* Rome, FAO: FAO, IFAD, UNICEF, WFP and WHO.
- [2] Rhoades, J. D. and Corwin, D. L., 1981. "Determining soil electrical conductivity – Depth relations using an inductive electromagnetic soil conductivity meter." *Soil Sci Am. J.*, vol. 45, pp. 225-260.

- [3] Kachanoski, R. G., Gregorich, E. G., and Van-Wesenbeeck, I. J., 1988. "Estimating spatial variation of soil water content using non contacting electromagnetic inductive methods." *Can. J. Soil Sci.*, vol. 68, pp. 715-722.
- [4] Ozegin, K. O. and Salufu, S. O., 2022. "Electrical geophysical method and GIS in agricultural crop productivity in a typical sedimentary environment." *NRIAG Journal of Astronomy and Geophysics, (Taylor and Francis)*, vol. 11, pp. 69-80.
- [5] Corwin, D. L. and Bradford, S. A., 2008. "Environmental impacts and sustainability of degraded water reuse." *J. Environ. Qual.*, vol. 37, pp. 1-7. Available: <https://doi.org/10.2134/jeq2008.0210>
- [6] Behrens, T. and Scholten, T., 2006. "Digital soil mapping in Germany - a review." *Journal of Plant Nutrition and Soil Science*, vol. 169, pp. 434-443.
- [7] Werban, U., Kuka, K., and Merbach, I., 2009. "Correlation of electrical resistivity, electrical conductivity and soil parameters at a long-term fertilization experiment." *European Association of Geoscientists and Engineers, Near Surface Geophysics*, vol. 7, pp. 5-14.
- [8] Islam, M. S., Saito, J. A., Emdad, E. M., Ahmed, B., Islam, M. M., and Halim, A., 2017. "Comparative genomics of two jute species and insight into fibre biogenesis." *Nat. Plants*, vol. 3, p. 16223.
- [9] Corwin, D. L. and Lesch, S. M., 2005. "Apparent soil electrical conductivity measurements in agriculture." *Computers and Electronics in Agriculture*, vol. 46, pp. 11-43.
- [10] Aigbedion, I. and Salufu, S., 2021. "Application of electrical geophysical method in site selection for viable area for agricultural practices: A case study of ukpenu-ibhiese and iruekpen Edo State-Nigeria." *AJGR*, vol. 4, pp. 44-54.
- [11] Blanco-Canqui, H. and LalR, 2007. "Soil structure and organic carbon relationships following 10 years of wheat straw management in no-till." *Soil and Tillage Research*, vol. 95, pp. 240-254.
- [12] McCauley, A., Jones, C., and Jacobsen, J., 2009. *Soil PH and organic matter, nutrient management, a self-study course from msu extension continuing education series Montana State University* vol. 8. Module, pp. 1-12.
- [13] Ulrike, W., Katrin, K., and Ines, M., 2009. "Correlation of electrical resistivity, electrical conductivity and soil parameters at a long-term fertilization experiment." *European Association of Geoscientists and Engineers, Near Surface Geophysics*, vol. 7, p. 14.
- [14] Omar, F. M., 2012. "Obtaining chemical properties through soil electrical resistivity." *J. Civ. Eng. Res.*, vol. 2, pp. 120-128.
- [15] Lowrie, W., 2007. *Fundamentals of geophysics. Second. Cambridge*. New York: Cambridge University Press Cambridge U.K.